



DESCRIPTION:

- Contemporary style.
- High gloss / Crack-resistant acrylic.
- Integral slotted overflow & pop up drain included.
- Complies with CSA & IAPMO standards.

AVAILABLE OPTIONS:

- Exterior colours.

JETTING OPTIONS:

- Comfort warm system.
- For ease of installation use our Freestanding Faucet and Pump Allaire module -

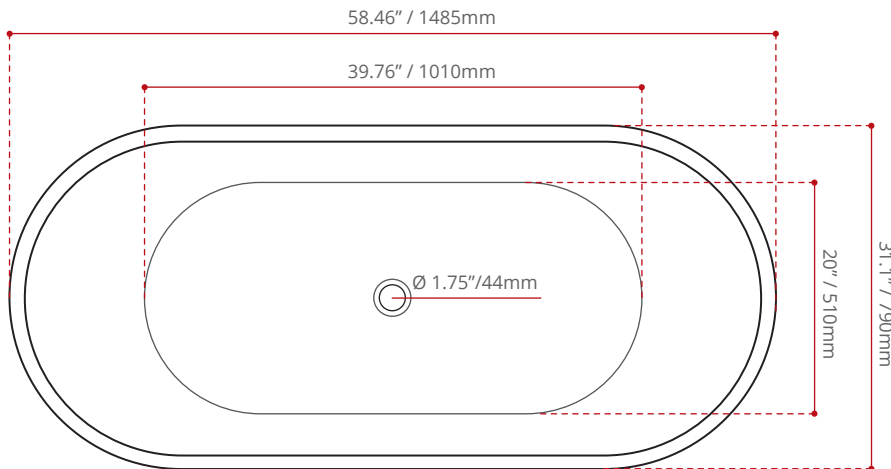

WATER DEPTH

15" / 381mm

CAPACITY

53 gal.
200 litres of water

SHIPPING DIMENSIONS

60 x 32 x 26" / 1524 x 813 x 660mm

NET WEIGHT

40 kg / 88 lbs

GROSS WEIGHT

54 kg / 119 lbs

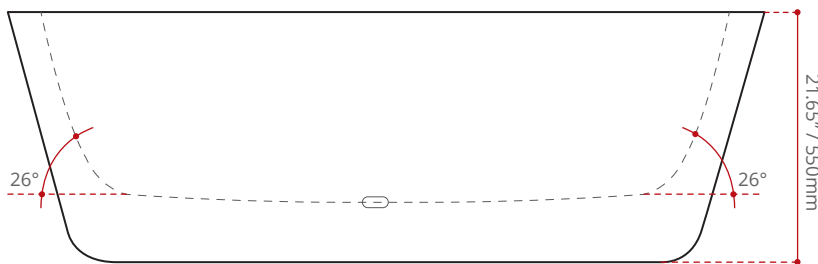

Measurements may vary \pm 5mm
- Diagram NOT to scale -

